

www.boscotek.com.au

THE ORIGINAL

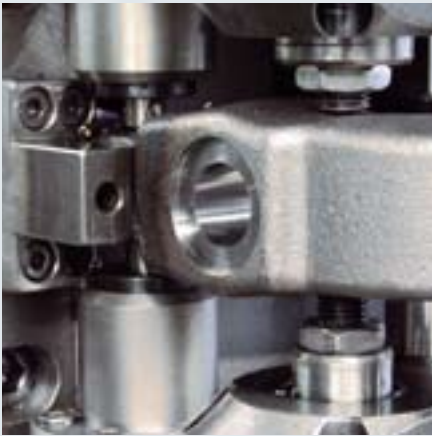

 **HEUER[®]**
Das Original

Foreword

We are pleased to present you our new catalogue and to introduce you to the company, our products and services on the pages that follow.

We draw your attention in particular to the original HEUER Vice. In 1925 Josef Heuer registered the patent on the drop forge bench-vice with the dual-prism guide track developed by him.

True to the motto „only those who have made history can tell the real story“, we have presented the success story over the years of the world-renowned HEUER Vice for you at the end of the catalogue.

One good product alone is not enough. For this reason we have also developed, along with the bench-vice and its accessories, other items in the same durable mould.

Innovative technology, optimal works procedure and highly qualified staff contribute to the basis of perfect production at Brockhaus Heuer.

Prompt delivery (48 hours after receipt of order as a rule) and personalised technical support from our technical representatives and our competent in-house team are considered standard in our company, as is the maintenance of the high quality of the products. We

challenge you to put our achievements to the test!

In the following pages you can acquaint yourselves with our products and trend-setting standards in quality, service and reliability, which our customers have come to put their trust in over the years.

Your BROCKHAUS-HEUER team

Contents

Company history	4
HEUER Vice	6
- Details	8
- With replaceable jaws	10
HEUER Compact	12
HEUER Protective jaws	14
HEUER Collapsible	16
HEUER Lift	18
HEUER Stand-lift	20
HEUER Collapsible-Lift	22
HEUER Rotary-Table	24
HEUER Table-Clamp	26
HEUER Clamp	28
History of the bench-vice	30
Contact	34

FLOURISHING

since 1864

1864
Friedrich Brockhaus founds a „factory shop“ for making iron and brass wire mesh in Kückelheim.

1874
Completion of a smithy for the production of lifting/ transportation lugs and parts for electric motors.

1874
Josef Heuer of Iserlohn registers the patent of his bench-vice.

1874
Debut of „HEUER Front“ at the Leipzig spring fair.

1874
Construction of a new machine park for improved bench-vice production.

1864

1909

1925

1936

1949

1874

Foundation of the drop-forge smithy and mechanical workshop in Oesterau.

1920

Founding of Brockhaus & Sons Company.

1927

Start of production of the patented HEUER parallel bench-vice system. Successful debut at the Leipzig autumn fair.

1937

Introduction of a training workshop.

1957

Alternative build of rotary table for the HEUER Vice.



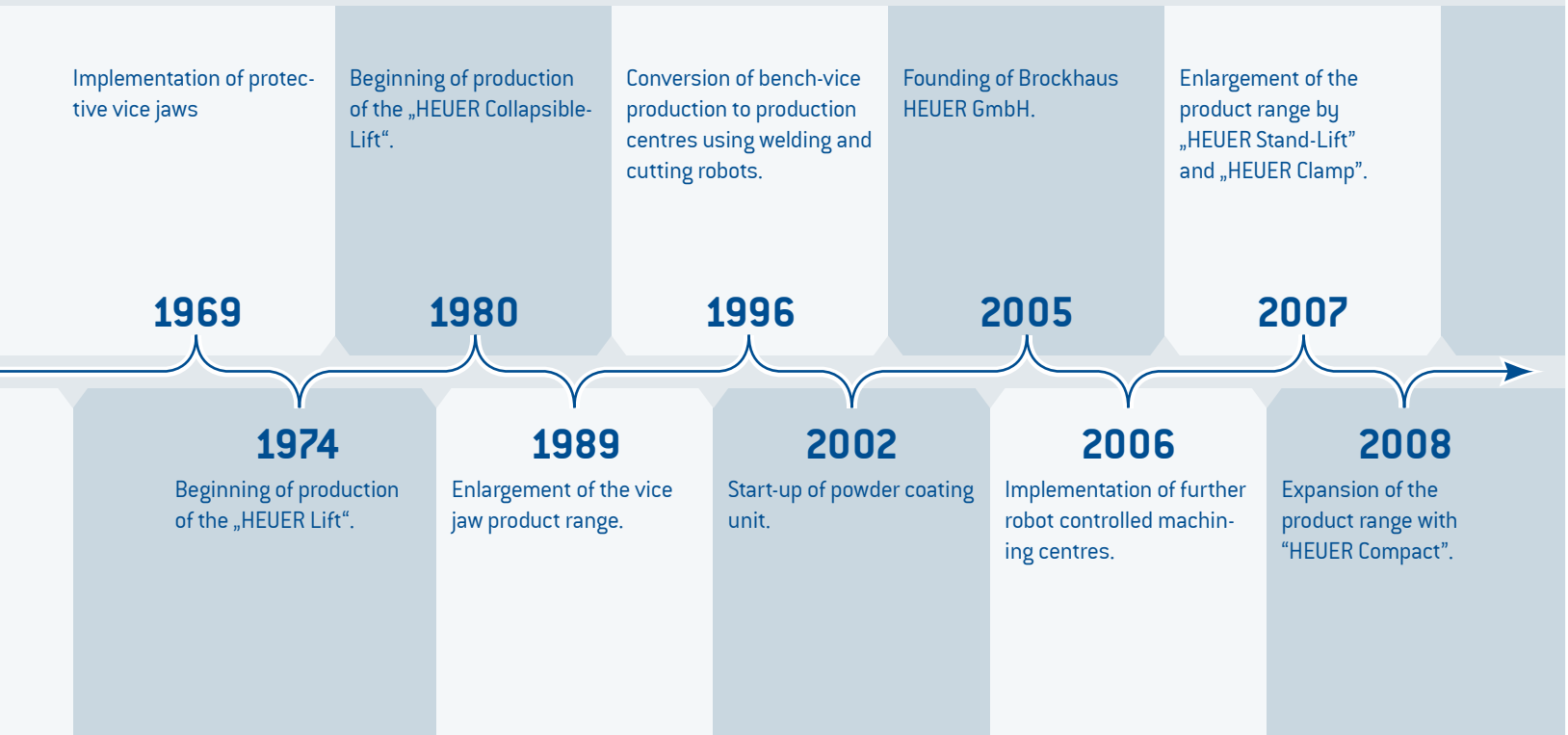



THE ORIGINAL

Made of pure steel

HEUER Vice

The HEUER Vice is a tool of the highest quality. Made purely of steel of guaranteed robustness. On account of its supreme individual components it overwhelms totally – with its reliability, durability and precision.

The drop-forge clamping jaw for example – recently series produced as standard – makes our flagship product so robust that we can guarantee its indestructibility.

Because of its narrow drop-forged guides, it offers an enhanced clamping depth. Internal dual-prism guide track design offers optimal protection against damage and fouling. Large track guide surfaces assure constant, smooth functioning of the guide rails, fully machined

to guarantee precision when working on sensitive workpieces.

An additional feature is the protected precision spindle bearing, the double-action trapezoid thread and the easily adjustable centrally located guide. This construction is conducive to its high precision. The spindle keys with riveted safety rings made of steel afford the required safety. An anvil is integrated in the rear jaw.

The HEUER Vice is a prime example of reliability and durability on account of its high quality and well-thought-out workmanship. Ideal for rough conditions in the workshop... And „Made in Germany“.

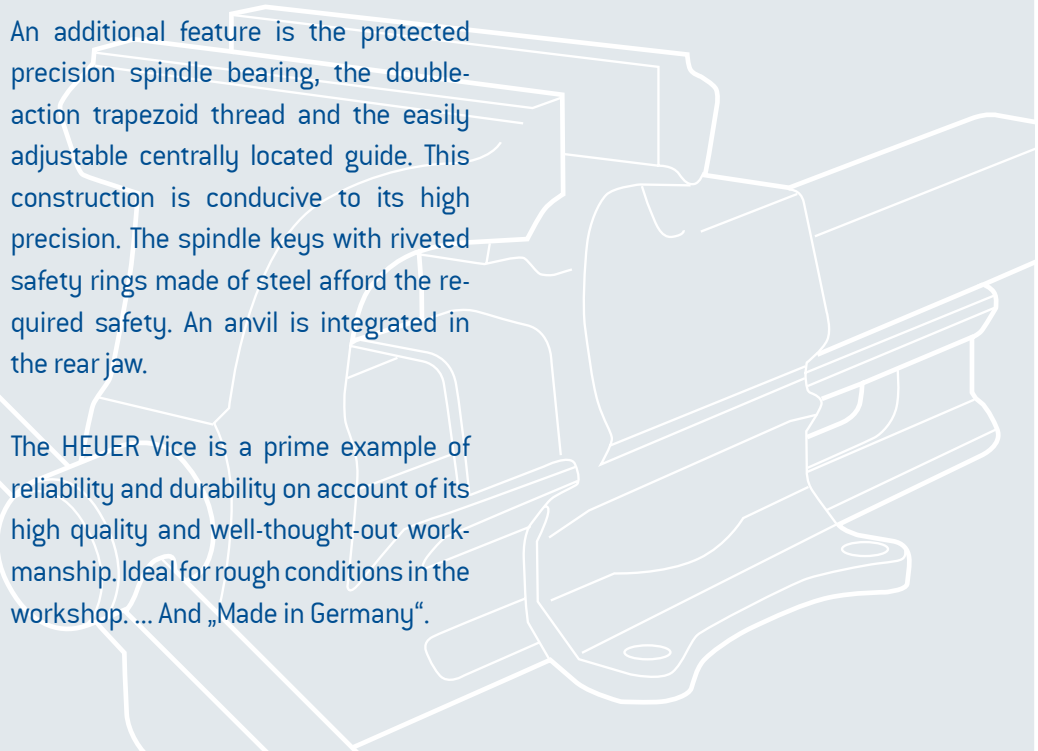

The protected precision spindle bearing is located within the drop-forged front jaw of the vice and is therefore optimised against damage and fouling. A feature that only the HEUER Vice offers in this form. The finished, drop



forged guiding brackets keep the sage-guard with double internal prismatic guideways accurately on course. It does away with annoying wobbles and instability.

	Width of jaw/mm	Span width/mm	Span depth/mm	Min-max. pipe-gripping jaw span-Ø/mm	Approx. Weight/kg	Item No.
100	125	50	16-30	4,5	100 100	
120	150	65	16-55	9,0	100 120	
140	200	80	27-70	16,0	100 140	
160	225	100	27-100	27,0	100 160	
180	225	100	27-100	29,0	100 180	



THE ORIGINAL

Details



1. Zinc spindle key with riveted safety rings made of steel

2. Drop-forged front jaw

3. Protected precision spindle bearing

4. Surface-hardened clamping jaws

5. Slim but stable guide tracks (drop-forged) provide greater clamping depth

6. High, optimally distributed clamping force from the centrally located and well-protected spindle with double-action trapezoid thread allowing quick opening and closing

7. Hardened pipe-gripping jaws as production standard

8. Drop-forged rear jaw with specially-formed anvil

9. Strong, forged spindle nut

10. Finished drop forged guiding brackets

11. Guide adjustable by centrally located screw

12. Internal dual-prism guide track preventing fouling and damages. Large track surfaces fully machined to guarantee precision and long service life

THE ORIGINAL

with replaceable, turnable jaws



HEUER Vice

For all heavy-duty conditions and even longer long service life.

HEUER Vice with screwed-on replaceable jaws - with corrugated and smooth work surfaces, available in sizes 120, 140 and 160 mm.

In order to meet all demands of the workshop we make our well-known steel HEUER Vices also in a special version with replaceable clamping jaws.

These surface-hardened jaws have one corrugated side and one plain side. They are adjustable and replaceable. The threads are located in the frontal jaws so that the valuable vice will not be rendered out of service by any damage to the clamping jaws.

The vices are in the same basic layout and can therefore be combined with all our other accessories (HEUER Lift/HEUERCollapsible/HEUERCollapsible-Lift/HEUER Stand-Lift/HEUER Rotary-Table/HEUER Table-Clamp/HEUER protective jaws).

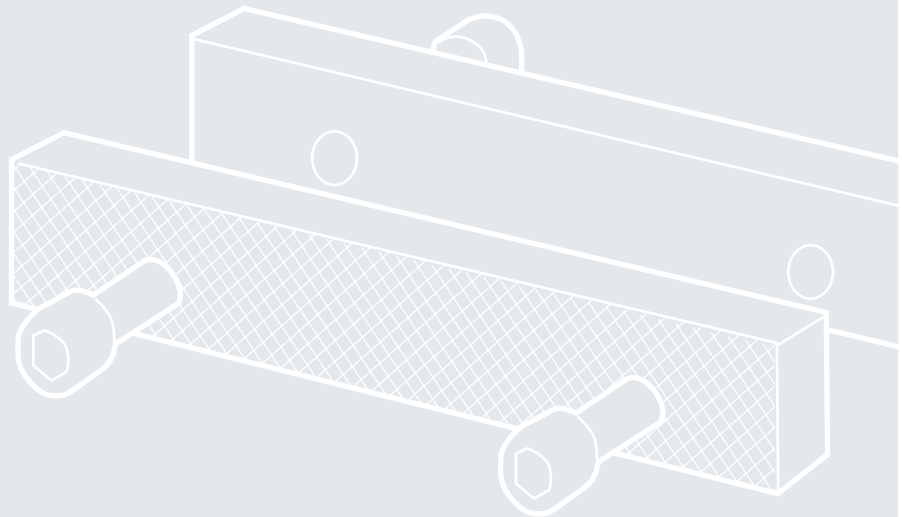

The replaceable jaws can be used on both sides. They are produced with a corrugated side and a plain side and are each fastened with Allen screws.

Overview of interchangeable jaws

Width/mm	Hole spacing/mm	Height/mm	Thickness/mm	Item No.
115,5	80	18	10	116 115
120,5	80	18	10	116 120
135,5	85	22	12	116 135
140,5	85	22	12	116 140
150,5	105	25	12	116 150
160,5	105	25	12	116 160

Overview of HEUER Vice with replaceable jaws

Width of jaw/mm	Span width/mm	Span depth/mm	Min+max. pipe-gripping jaw span-Ø/mm	Approx. Weight /kg	Item No.
120	150	65	16-55	9,0	101 120
140	200	80	27-70	16,0	101 140
160	225	100	27-100	27,0	101 160

Compact

GRIP FORCE

small, fast, flexible



HEUER Compact

With revolutionary HEUER Quicklaunch

With a weight of 4.5 Kg and a powerful gripping power of 10 kN it is the lightweight in its category. Of course the HEUER Compact offers enhanced clamping depth options and it is remarkably expandable with many standard accessory items from BROCKHAUS HEUER.

The HEUER Compact thanks its name to its very efficient design. Functionality was a key factor here and this with the customary high quality of BROCKHAUS HEUER.

WORLD NOVELTY: HEUER Quicklaunch
The ingenious thing about it is the all new, revolutionary quick adjusting HEUER

Quicklaunch. Thanks to this, large jaw width differences can be adjusted on the HEUER Compact in just the turn of a hand – from 0 to 130 mm in 3 seconds. Without operating the handle. The width gauge helps in the pre-adjustment. In the process the parallelism of the jaws when clamping is not affected by the tolerance of the spindle, which is necessary for an optimally functioning quick adjustment. A pressure spring warrants the safe locking in the desired position. This is also audio-visually perceptible.

The exchangeable, turnable jaws with smooth and grooved clamping surface create even more flexibility. The HEUER

Compact is additionally equipped with pipe-gripping jaws integrated in the front and rear jaw. It too can be added on to. For example with the HEUER Table Clamp 100 or with the HEUER Rotary Table 100 and a large selection of magnetic protective jaws.

The HEUER Compact – our all-rounder in a mobile format.



Width of jaw/mm	Span width/mm	Span depth/mm	Min+max. pipe-gripping jaw span-Ø/mm	Approx. Weight/kg	Item No. Compact
120	130	65	15-50	4,5	118 001

Width of jaw/mm	Item No. Spare jaws
120,5	116 120



Individual **INTERCHANGEABILITY**

HEUER protective jaws

HEUER protective jaw blocks have a strong basic form made out of Aluminium or are produced completely out of Polyurethane (PP and PR). The profile is right-angled and the faces are flat and parallel; the high precision of the HEUER Vices are maintained. The integral special magnets hold the protective jaw blocks securely on the vice. Despite extremely high magnetic force, the magnetism does not penetrate the clamping faces, so that neither the clamping force of the blocks is affected, nor a magnetising of the piece takes place.



Type PP
(Polyurethane prism)

Clamping of delicate round and oval workpieces

The jaws are made of polyurethane. This highly flexible, resistant and non ageing material is tending to assume the original shape after a deformation by pressure. The work pieces are fixed by means of different sized integrated prisms.



Type G
(Rubber)

Clamping of thin walled tubes and shaped pieces, wood and plastic parts

The clamping faces are produced from a special synthetic rubber. Three layers of a canvas material oppose the natural spring tendency of the rubber during the clamping process. The workpieces are held secure even when very low forces are applied.



Type PR
(Polyurethane grooved)

Clamping of all types of delicate workpieces

The material properties are of identical type as the PP-design. The corrugation of the jaws grips the surface without damaging it.



Type Fi
(Felt)

Clamping of extremely delicate workpieces

The faces of the jaw blocks are special abrasion resistive felt that matches closely the contours of the workpieces. Even the most delicate workpieces are held securely without any damage.



Type F
(Fibre)

Clamping of workpieces with finely machined or polished faces

The faces of the jaw blocks are special abrasion of layers of fibres. There is no deformation of the faces even when clamping warm workpieces.



Type N
(Neutral)

Clamping of rough to medium machined workpieces

The jaw blocks are made out of Aluminium and have a hardness factor between that of copper and lead. 6 grooves hold the workpieces secure. A deeper groove serves to hold shafts and pins etc. secure.



Type P
(Prism)

Clamping of workpieces of various shapes

The jaw blocks are made out of Aluminium with a hardness factor between that of copper and lead. One horizontal prism and three different vertical prisms facilitate clamping of round or oval workpieces. The 90° cutout in the upper part of the jaw blocks facilitate problem free and horizontal clamping of flat material.

Article number summary (available in pairs)

Width of jaw in mm	Type PP	Type PR	Type F	Type P	Type G	Type Fi	Type N
90	–	–	111 090	109 090	112 090	113 090	110 090
100	108 100	107 100	111 100	109 100	112 100	113 100	110 100
115	–	–	111 115	109 115	112 115	113 115	110 115
120	108 120	107 120	111 120	109 120	112 120	113 120	110 120
125	–	–	111 125	109 125	112 125	113 125	110 125
135	–	–	111 135	109 135	112 135	113 135	110 135
140	108 140	107 140	111 140	109 140	112 140	113 140	110 140
150	–	–	111 150	109 150	112 150	113 150	110 150
160	108 160	107 160	111 160	109 160	112 160	113 160	110 160
175	–	–	111 175	109 175	112 175	113 175	110 175
180	–	–	111 180	109 180	112 180	113 180	110 180

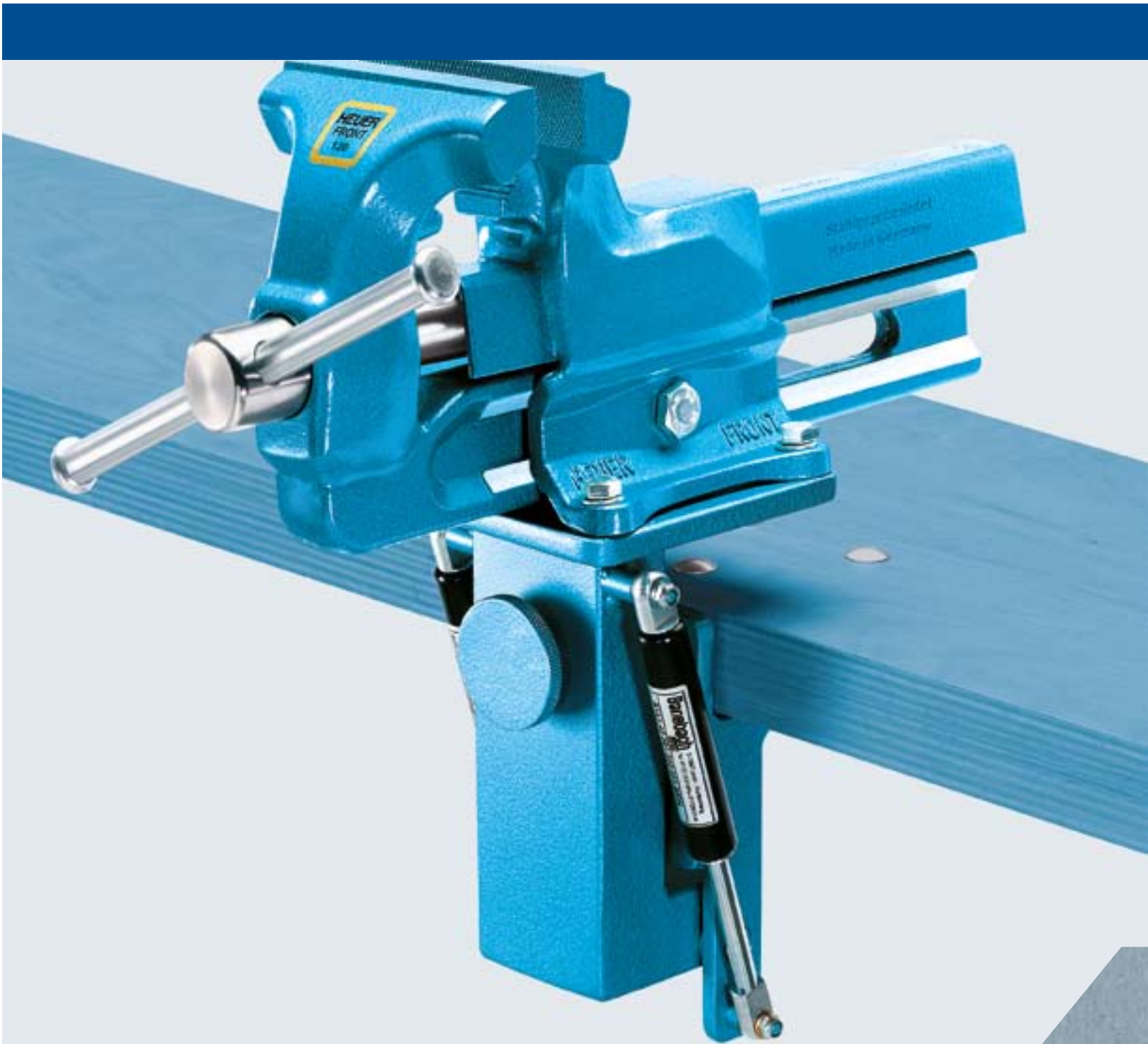

Collapse

ERGONOMICS¹

HEUER Collapsible

More space on the workbench

Collapse, fold and stow. The ideal complement for the bench-vice. The HEUER Collapsible can be stowed under the workbench with ease creating extra space when not in use. The HEUER Collapsible provides an especially ergonomic solution to clustered workspaces in the workshop. In its working position, the vice is fixed sturdily to the workbench and free of any vibration.

When additional height adjustment and rotating capability are needed, the HEUER Collapsible-Lift on the following pages is the right choice.

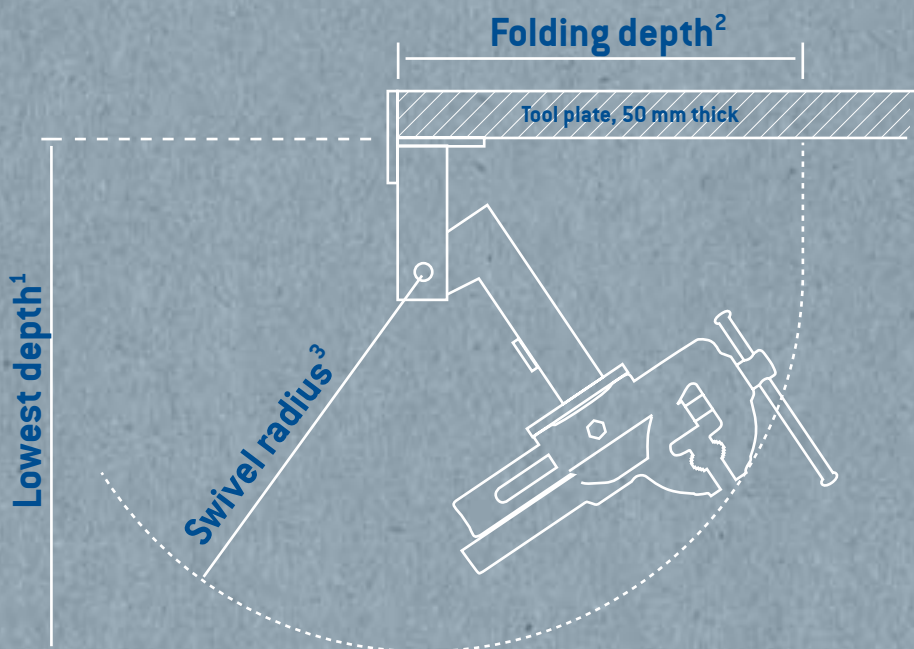
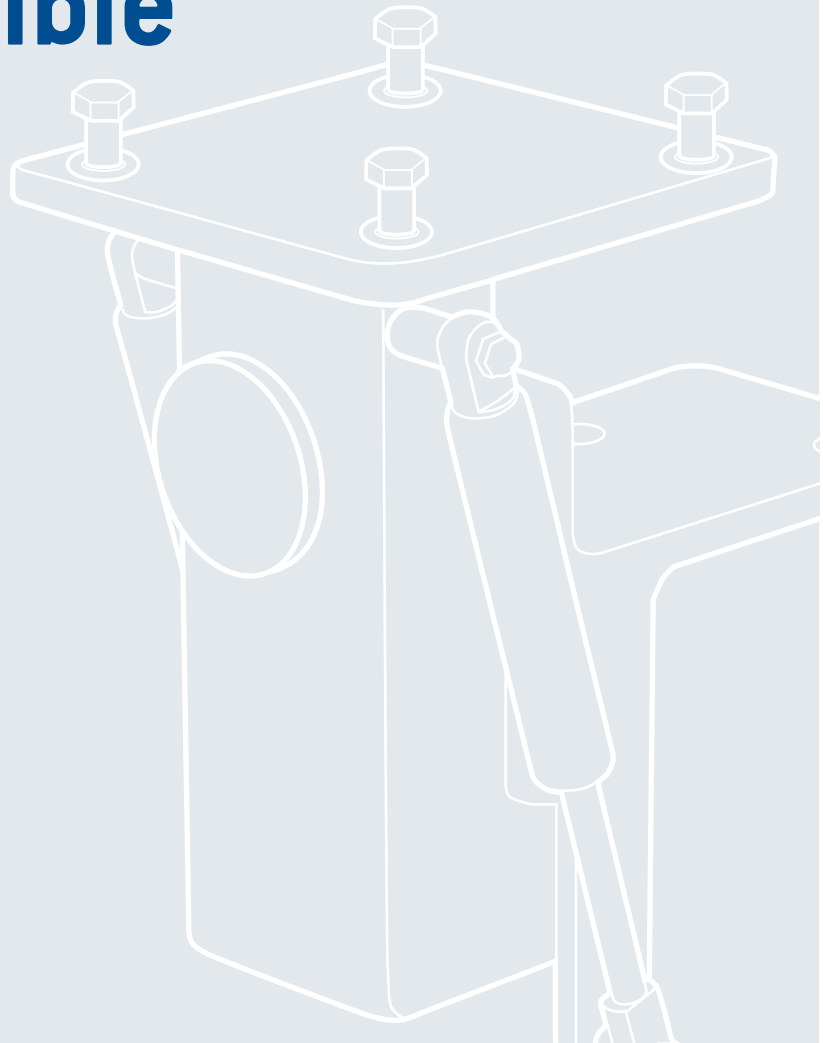

	Width of jaw/mm*	Lowest depth/mm 1	Folding depth/mm 2	Swivel radius/mm 3	Item No.
120	495	410	390	105 120	
140	535	455	430	105 140	

* Data refers to HEUER Vices.

¹ From lower edge of workbench plate

² From front edge of workbench plate

³ Around point of rotation



Lifting, rotating

ERGONOMICS²

HEUER Lift

HEUER Lift height adjustment for the HEUER Vice. The perfect complement for an ergonomic workplace.

No matter which differing body sizes, tool sizes and type of work to be carried out, HEUER Lift units enable the perfect operating position to be adjusted effortlessly to the vice.

The adaptation of the vice to body size is an especially important factor for trainees in schools or trainee workshops, in order to avoid incorrect body posture and its serious consequences. Items of different height, sizes and shapes requiring a variety of work, are effortlessly accommodated with the HEUER Lift equipment. The vice can be adjusted with ease

to a height of 200 mm and rotated through 360°.

A gas shock absorber, specially tuned to the weight of the vice, makes the vice practically weightless. The vice is then locked in place at the optimum working position.

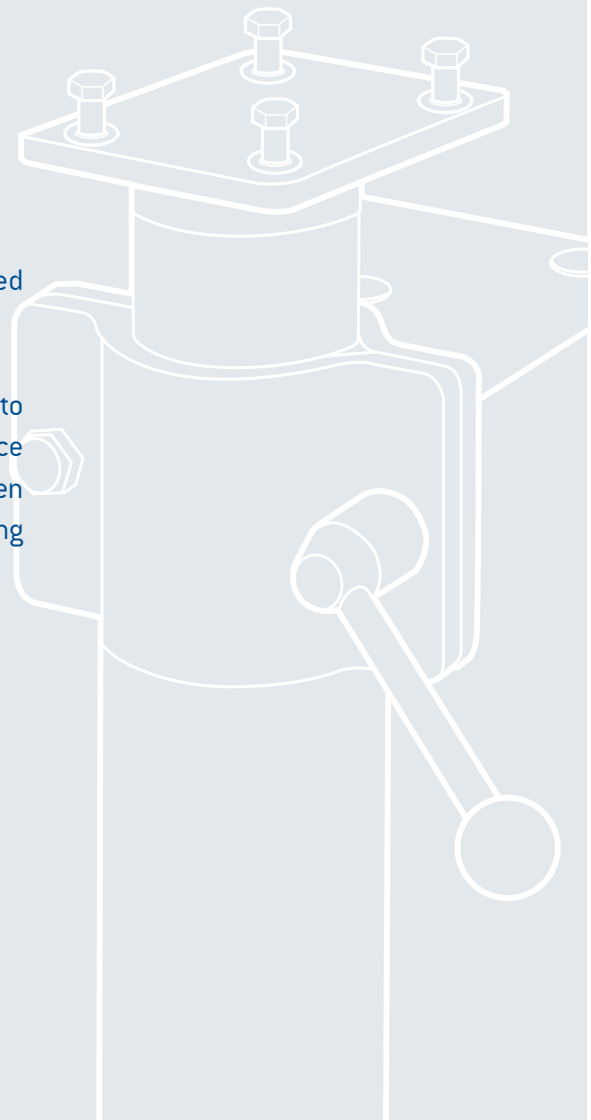

Width of jaw/mm*	Permitted loading/kg	Item No.
100	4 - 10	104 200
120	4 - 10	104 220
140	10 - 16	104 240
160/180	16 - 29	104 260

* Data refers to HEUER Vices. Also suitable for other makes provided that permitted loading weights are observed. When ordering please do not forget details of make and size.





Lift, rotate
ERGONOMICS²⁺
unattached

HEUER Stand-Lift

The HEUER Stand-Lift is the perfect supplement to the Heuer Vice for ergonomic working without a workbench.

No matter which differing body sizes, tool sizes and type of work top be carried out, HEUER Stand-Lift units enable the perfect operating position to be adjusted effortlessly to the vice.

The adaptation of the vice to body size is an especially important factor for trainees in schools or trainee workshops, in order to avoid incorrect body posture and its serious consequences.

Items of different height, sizes and shapes requiring a variety of work, are effortlessly accommodated with the HEUER Stand-Lift equipment. The vice

can be adjusted with ease to a height of 200mm and rotated through 360°.

The main attraction:
An extremely sturdy stand support makes flexible working in limited space possible, without a workbench. This allows working on bulky work pieces from all sides without any hindrances.

A gas shock absorber, specially tuned to the weight of the vice, makes the vice practically weightless. Once the clamp lever has been released the vice can easily be brought into the desired work position.

Needless to say that the HEUER Stand-lift can be used in combination with a wide range of other devices and equip-

ment, such as bench grinders or small worktops.

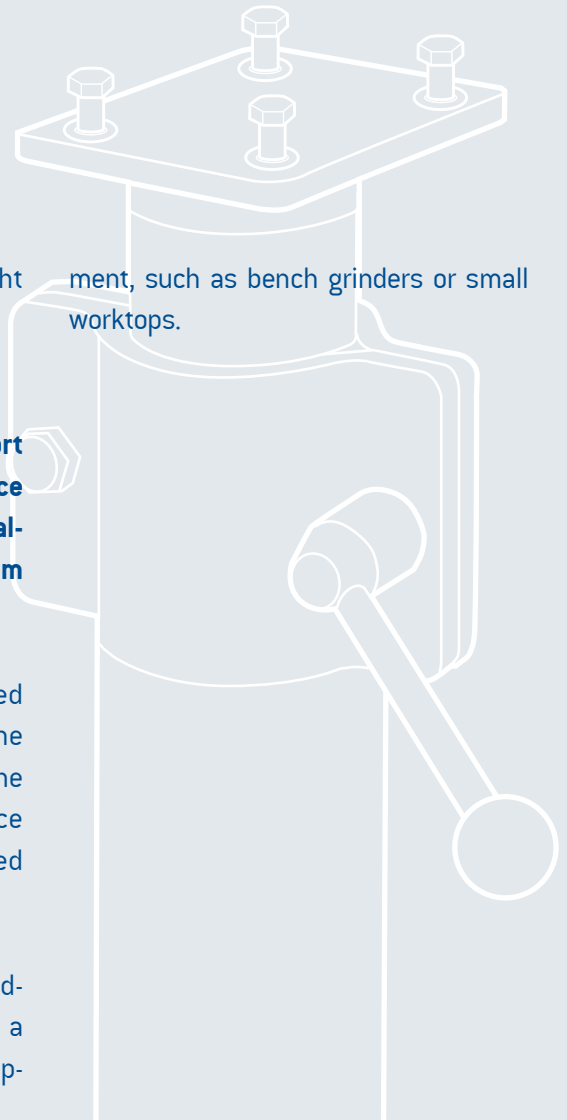

The HEUER Stand-Lift is immovably secured at the installation location with four foundation screws.



Width of jaw/mm*	Approx. Weight/kg	Permitted loading/kg	Item No.
120	21	4 - 10	117 120
140	21	10 - 16	117 140
160/180	21	16 - 29	117 160

* Data refers to HEUER Vices. Also suitable for other makes provided that permitted loading weights are observed. When ordering please do not forget details of make and size.



Collapse, lift, rotate

ERGONOMICS³

HEUER Collapsible-Lift

Collapse, lift, rotate. Three advantages in one unit.

When not in use the vice can be folded beneath the workbench thus freeing the whole workspace for other work.

The adjustability of the vice extends to approx. 175 mm in height and to rotatability of 360°.

People of different sizes, items of different height, sizes and shapes requiring a variety of work, are effortlessly accommodated with the HEUER Collapsible-Lift equipment.

A real boon to the workplace that prevents serious posture damage – espe-

cially important for trainees in schools and workshops.

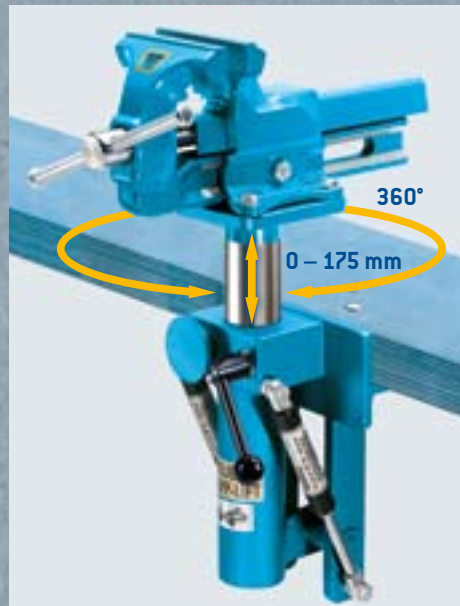
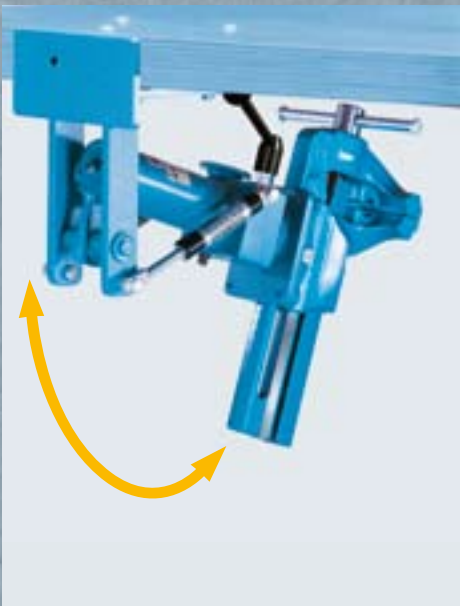
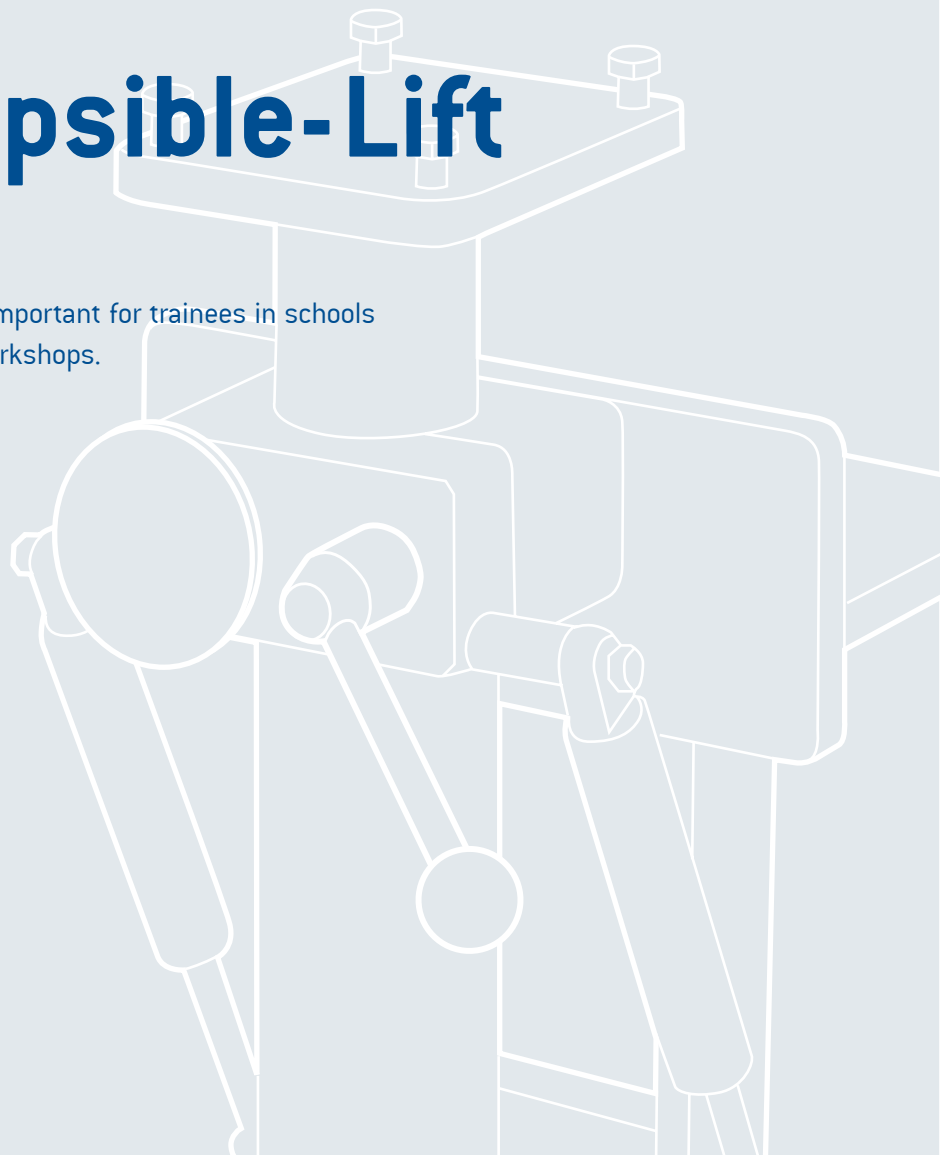

Width of jaw/mm *
Lowest depth/mm 1
Folding depth/mm 2
Swivel radius/mm 3
Permitted loading/kg
Item No.

120	590	460	430	4-10	106 120
140	630	495	470	10-16	106 140

* Data refers to HEUER Vices. Also suitable for other makes provided that permitted loading weights are observed. When ordering please do not forget details of make and size.

¹ From lower edge of workbench plate (-> page 17)

² From front edge of workbench plate (-> page 17)

³ Around point of rotation (-> page 17)



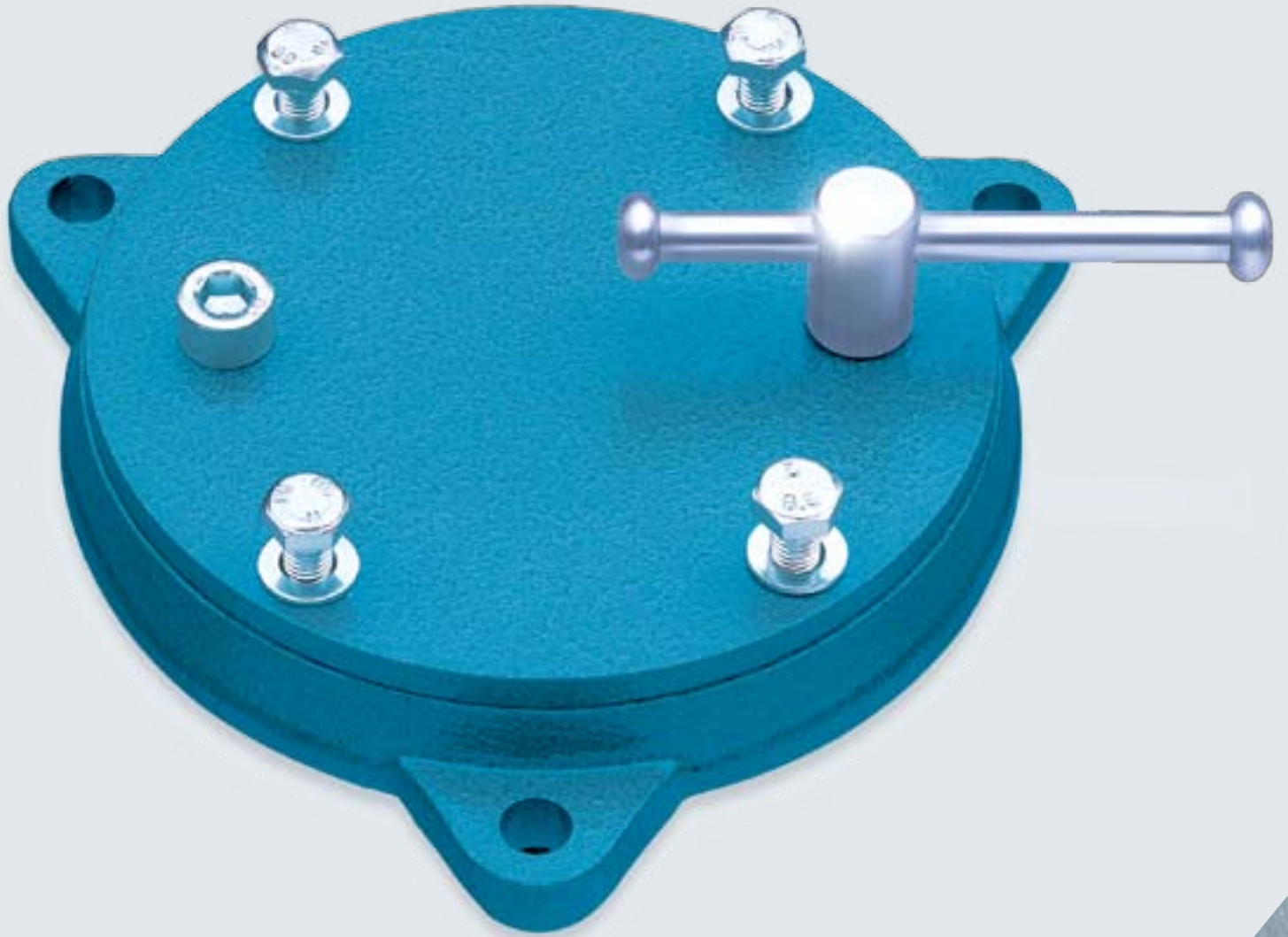

Effortless
ERGONOMICS OF MOVEMENT

HEUER Rotary-Table

Make working with the HEUER Vice even more flexible.

Thanks to the HEUER Rotary-Table the vice can be rotated 360° on one level exactly in the position that you need for working on a given item. The robust setting with a small spindle key enables the rotary table – and therefore the vice – to be precisely and firmly set to the required position.

Their build determines the uniquely positive features. The HEUER Rotary-Table comes with a covered plate in order to prevent entry of dirt and shavings into the guide. The steel rotating unit and carrying plate fit exactly into

one another and thus assure a precise guide. The guide surfaces are of course conceived to provide as resistance-free an operation as possible.

The HEUER Rotary-Table is of an especially flat build to assure great stability. The HEUER Rotary-Table is designed for all vice sizes.

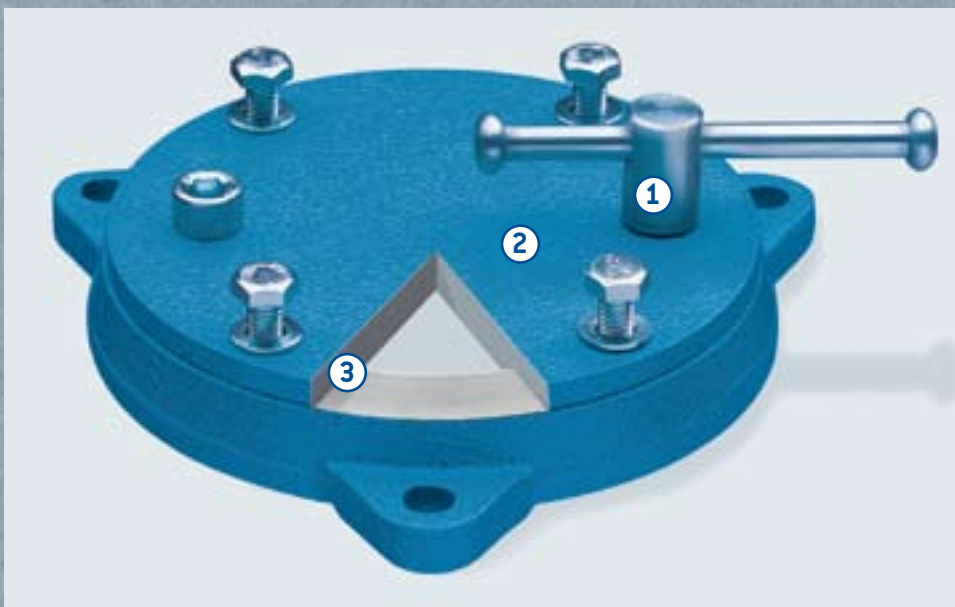
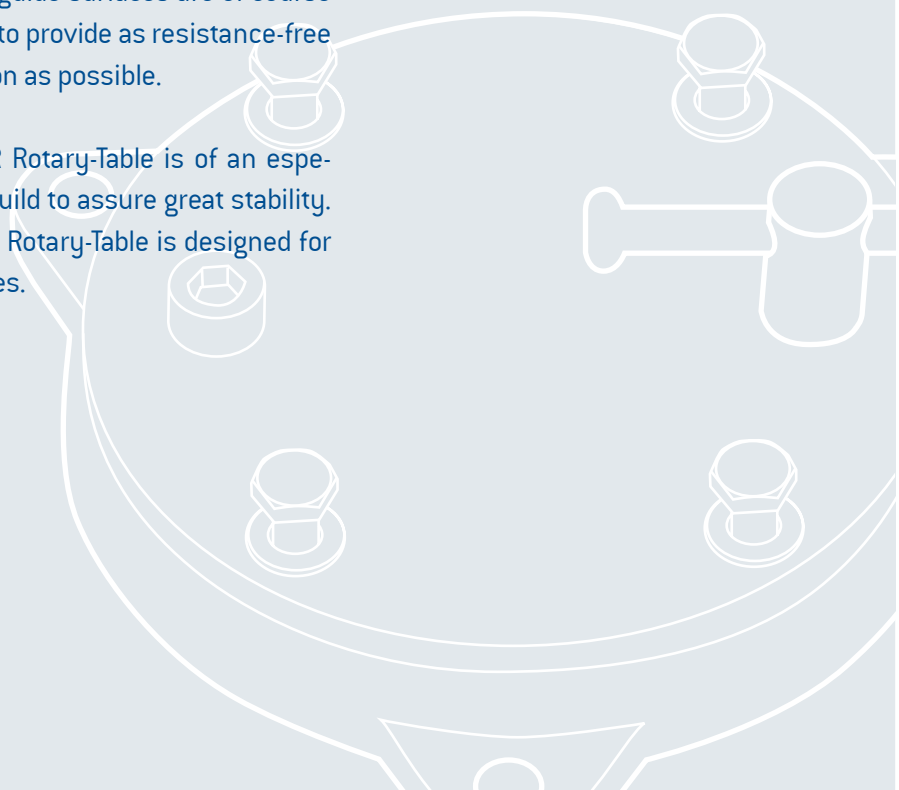

1. Can be set to any position quickly and firmly
2. Covered carrying plate prevents entry of shavings and dirt
3. The steel rotating unit and carrying plate designed for exact guidance

Width of jaw/mm*	Approx. Weight /kg	Item No.
100	1,8	103 100
120	2,5	103 120
140	5,0	103 140
160/180	7,5	103 160

* Data refers to HEUER Vices.



THE CLAMP

HEUER Table-Clamp

Flexible without need for boring.

The HEUER Table-Clamp is perfect for fastening the vice firmly to the working plate. With it, the vice – without the necessity of boring holes – can be mounted and removed from the working plate rapidly and without damage. This frees up space on the work surfaces and avoids the time-consuming mounting and removal of the whole vice from the workbench.

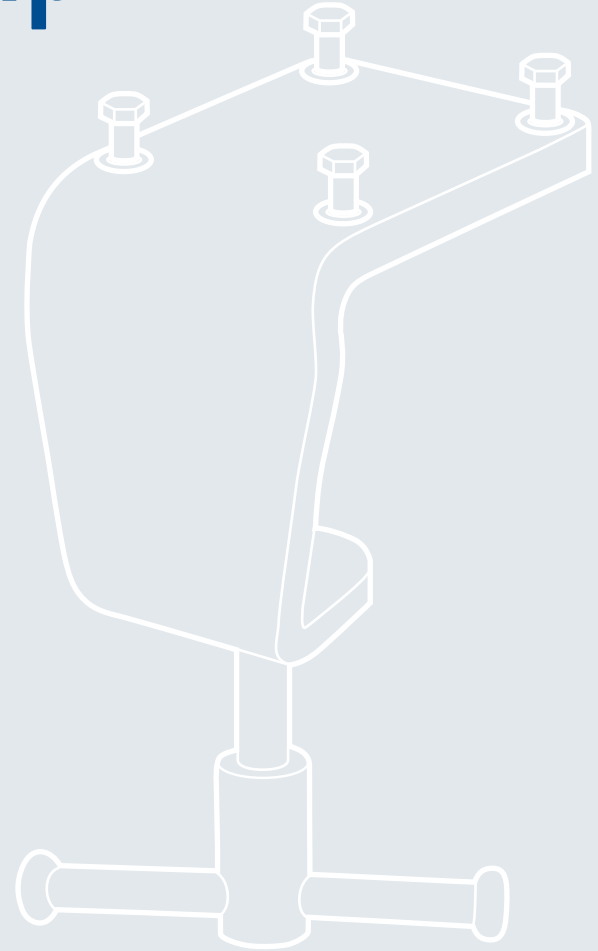

The HEUER Table-Clamp can be installed and removed simply and rapidly with a few movements. The sturdy wing bolt assures easy and safe operation. The four screw receptacles are set to 100 and 120 on the HEUER Vice.

	Width of jaw/mm*	Approx. Weight/kg	Table top thickness/mm	Item No.
100	1,0	10 - 60	119 100	
120	1,7	10 - 60	119 120	

* Data refers to HEUER Vices.



CLAMPED
right on the spot
fast, right-angled, easy

HEUER Clamp

The ultimate helper in mould making, tool making and mechanical engineering as well as in maintenance departments.

The HEUER Clamp is the perfect tool for light to medium metal cutting applications. Expressly suitable for the fixation of two-dimensional semi-finished products that are too big for a machine vice.

Advantage 1:

The work piece is quickly and precisely aligned parallel to the axis and/or to the grooves of the machine without the need for time consuming alignment. Due to its two guide pins the HEUER Clamp always sits parallel in the grooves of the machine! This makes right angled clamping possible.

Advantage 2:

Because of the free space between semi-finished product and machine, drilled holes, free millings and cut-outs are not a problem. The surfaces of semi-finished products can be almost completely worked on. By using several HEUER Clamps even larger semi-finished products can be comfortably and easily aligned, clamped and worked on.

Advantage 3:

Several work pieces of the same type can be identically clamped without re-aligning because only the chuck head is loosened. The stop position remains the same. When using the HEUER Clamp a

great time advantage can be reached in comparison to conventional clamping methods.

Clamping strength: approx. 35 KN (per Heuer Clamp). Plane parallelism: 0,02 mm.

For the use on diverse machine sizes the corresponding adapters of the HEUER Clamp are exchanged. The adapter sets are available in the sizes: 12, 14, 16, 18 mm.

One adapter set includes two alignment pins (1) and a T-slide (2).

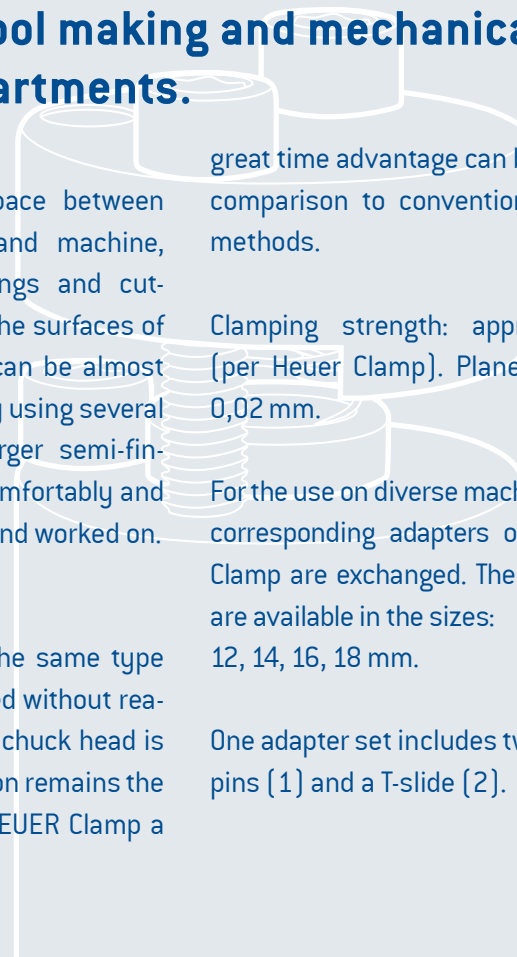

One requires at least three HEUER clamps. Any further clamps serve to better clamp the work piece.

Using longer screws makes the possible clamping height basically unlimited, the screws included allow clamping up to 4 – 45 mm material thickness.

Adapter set:



The HEUER Spann is protected by registered design.

Groove width / mm	Approx. Weight / kg	Item No. Heuer Clamp	Item No. Adapter set
12	1,7	213 012	213 001
14	1,7	213 014	213 002
16	1,7	213 016	213 003
18	1,7	213 018	213 004

The bench-vice history

An indispensable tool and its origin.

In the mists of the distant past, whoever came upon the idea of fixing items to be worked on in such a way that they would not move under the pressure of sawing, filing and boring, is unknown. The astonishing fact is that today in the computer age, the vice as a purely mechanical tool is indispensable; and no workshop crammed with electronic devices can do without it.

A decisive step in the development of this indispensable tool into its present form was the replacement

of clamping techniques using wedge and hammer by clamps with threads in the middle ages. The disadvantage: the moving jaws could only be guided radially so that the clamped items would more or less tilt.

It was only with the introduction of the parallel vice in 1750 on which the movable jaws were guided on horizontal adjustable slots that a breakthrough was made to the optimal application.

In 1830 in England the first cast iron vice was produced. Liquid iron could be transformed into any shape eas-

ily. When pouring, air pockets often occurred within the cast, so-called cavities. The structure was therefore porous and brittle. The result: insufficient resistance for harder tasks, causing breakage. For this reason, for example, parts vital for safety in the car industry and high-grade unbreakable vices are made of steel. The structure of the steel is made homogeneous through forging. With the introduction of the jackhammer with its heavy hammering capability and the use of forges with strict tolerances, the problem of accurate shaping was solved.



Spindle production



Welding robot

The birth of the HEUER Vice

When Josef Heuer, the experimenter and inventor from Iserlohn, invented a new build of drop-forged vice with its revolutionary dual-prism guide track in 1925, the Brockhaus company in Plettenberg, Sauerland, was already one of the largest drop-forges in Germany. The significance of the invention was recognised as far-sighted. The patent was applied for in 1927, and thus started the production of this vice. This marked the arrival of the world famous and million-selling HEUER Vice.

A successful beginning and development

The chronicle says: „in the same year, with a great deal of effort a new vice was successfully exhibited at the Leipzig autumn fair for the first time, and considerable orders for it was the result“. No wonder then, that the guaranteed unbreakable pure steel „HEUER Primus“ reached record distinction at the top of its class. This success did not allow Brockhaus technicians to sit on their laurels. They developed a vice along with the HEUER Primus, which opened at the rear, a vice that opened at the front – in the direction



Partial view of training centre



Quality control in the production centre

of the operator. Thus, clamping and work on even large items vertically in front of the workbench became possible. The new model was appropriately named HEUER Front. The operability of the HEUER Front was further improved on and its versatility increased. In this way the dual-prism guide thread provided a sturdy, precise and fast clamping force and the forged pipe-gripping jaws for additional applications. Dedicated tubular vices then become superfluous.

The path to a perfect tool

After the second world war, work begun

at Brockhaus on new products with great dedication. At the time of the German recovery, vices were in greater demand than ever. Among other things, the etiquette „Made in Germany“ for technical products made for worldwide success. A word on „Made in Germany“: HEUER Vices have been made in Germany alone for more than 80 years.

Advanced production methods, particularly in welding and forging, spurred the inventor Josef Heuer to seek a new patent in 1948. Today's HEUER Vice is based on the concept of this patent.

In parallel to the perfection of the production methods, Brockhaus techni-



Fully automatic depot and distribution centre



Cutting robot

cians worked on the improvement of models according to the principle: „small details have great consequences“. Through a pressure disc, spring and snap ring for example, the spindle was thus positioned so that lost motion was eliminated.

These days the HEUER Vice has a centrally adjustable guide, forged jaws as standard, a protected spindle location, and, because of its slimness due to its drop-forged guide rails – an advantageous low clamping capability.

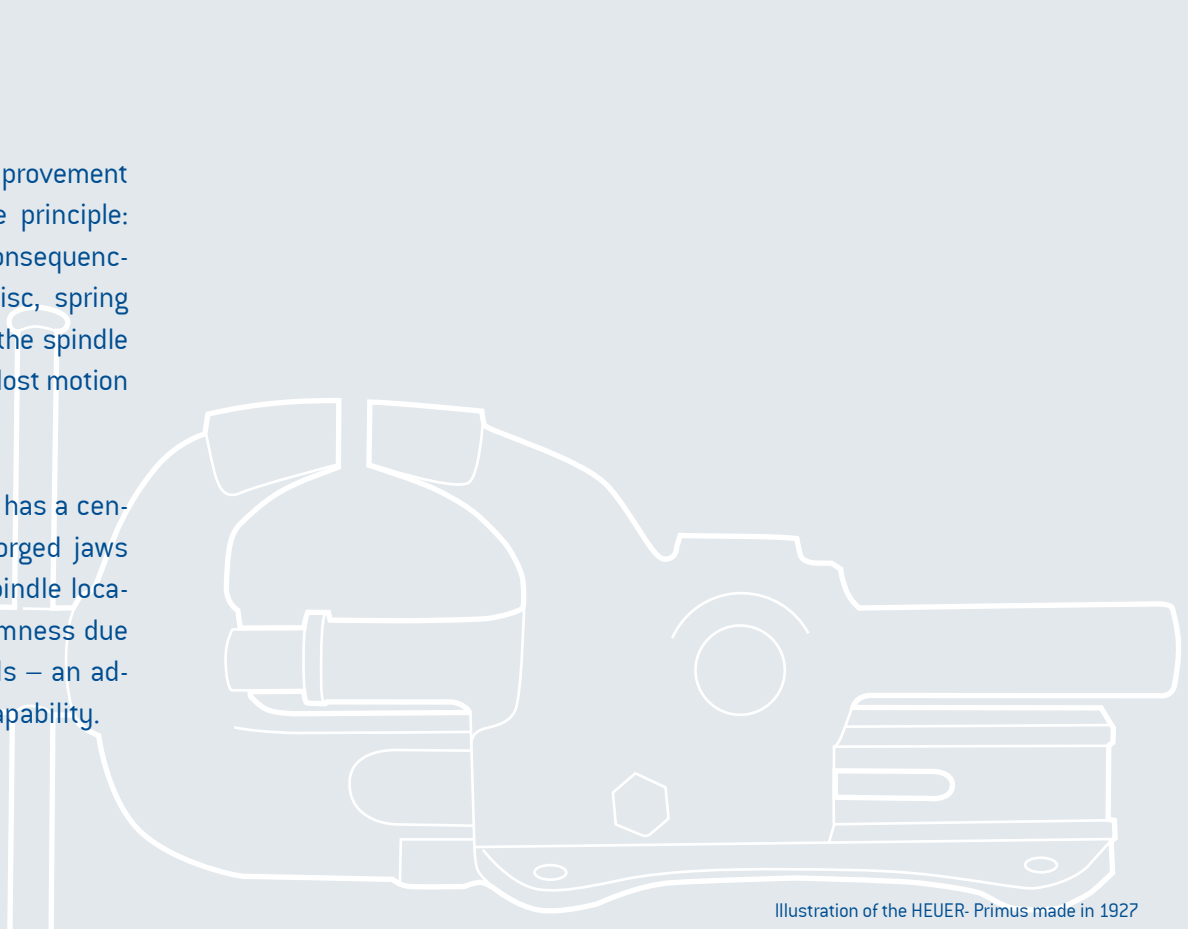

Illustration of the HEUER- Primus made in 1927



Powder coating unit



Distribution centre

Contact



Boscotek Industrial Storage

24 Williamson Road, Ingleburn NSW 2565

Ph: 02 8796 6288 | **Fax:** 02 8796 6289

Email: info@boscostorage.com.au | **Web:** www.boscotek.com.au



Robust
Präzise Vielseitig
Sicher
Robust
Präzise
Sicher
seit 1927
Robust
Vielseitig
Langlebig
Spannkräftig
Sicher Schnell
Vielseitig
Robust
Präzise
Spannkräftig
Das Original

